



FUJII ELECTRIC

**SPLIT TYPE
ROOM AIR CONDITIONER
WALL MOUNTED type**

SERVICE MANUAL



Models

Indoor unit

RSA14LCC

RSA18LCC

Outdoor unit

ROR14LCC

ROR18LCC

CONTENTS

SPECIFICATIONS	1
DIMENSIONS	2
REFRIGERANT SYSTEM DIAGRAM	3
CIRCUIT DIAGRAM	4
INDOOR PCB CIRCUIT DIAGRAM	5
OUTDOOR PCB CIRCUIT DIAGRAM	6
ERROR CONTENTS	8
DISASSEMBLY ILLUSTRATION	9
PARTS LIST	13
STANDARD ACCESSORIES	15

FUJITSU GENERAL LIMITED



Большая библиотека технической документации

<https://splitsystema48.ru/instrukcii-po-ekspluatacii-kondicionerov.html>

каталоги, инструкции, сервисные мануалы, схемы.

SPECIFICATIONS

TYPE	COOL & HEAT INVERTER	
INDOOR UNIT	RSA14LCC	RSA18LCC
OUTDOOR UNIT	ROR14LCC	ROR18LCC
COOLING CAPACITY	4.20 kW	5.20 kW
HEATING CAPACITY	5.60 kW	6.25 kW

ELECTRICAL DATA

POWER SOURCE		230 V	
FREQUENCY		50 Hz	
RUNNING CURRENT	COOLING	5.0 A	7.6 A
	HEATING	6.4 A	7.7 A
INPUT WATTS	COOLING	1.11 kW	1.72 kW
	HEATING	1.45 kW	1.73 kW
E.E.R.	COOLING	3.78 kW/kW	3.02 kW/kW
COP	HEATING	3.86 kW/kW	3.61 kW/kW
MOISTURE REMOVAL		2.1 L/hr	2.8 L/hr
AIR CIRCULATION-High	COOLING	700 m3/hr	700 m3/hr
	HEATING	700 m3/hr	700 m3/hr

COMPRESSOR

TYPE	Hermetic type, 4 pole, 3 phase, DC inverter motor, Rotary	
DISCRIMINATION	DA130A1F-25F	
REFRIGERANT	R410A	1,150 g

FAN MOTOR

POWER SOURCE		230 V	
INDOOR UNIT (cool / heat)	HIGH-SPEED	1,480 r.p.m. / 1,480 r.p.m.	
	MED-SPEED	1,260 r.p.m. / 1,300 r.p.m.	
	LOW-SPEED	1,040 r.p.m. / 1,110 r.p.m.	
	QUIET	850 r.p.m. / 950 r.p.m.	
OUTDOOR UNIT (cool / heat)		820 / 750 r.p.m.	860 / 820 r.p.m.

DIMENSIONS

INDOOR UNIT	H x W x D	275 x 790 x 215 mm
OUTDOOR UNIT	H x W x D	578 x 790 x 300 mm

WEIGHT

INDOOR UNIT	GROSS / NET	12 / 9 kg
OUTDOOR UNIT	GROSS / NET	44 / 40 kg

NOISE LEVEL

INDOOR UNIT (cool / heat)	HIGH-SPEED	44 dB / 42 dB	
	MED-SPEED	38 dB / 37 dB	
	LOW-SPEED	32 dB / 32 dB	
	QUIET	25 dB / 27 dB	
OUTDOOR UNIT (cool / heat)		48 dB / 49 dB	50 dB / 50 dB

REFRIGERANT (R410A)

FULL CHARGE AMOUNT	Pipe Length	15 m	1,150 g
		20 m	1,250 g
ADDITIONAL REFRIGERANT		20 g / m	
MAXIMUM PIPE HEIGHT		15 m	

DIMENSIONS

Models :

RSA14LCC / ROR14LCC

RSA18LCC / ROR18LCC

(unit : mm)

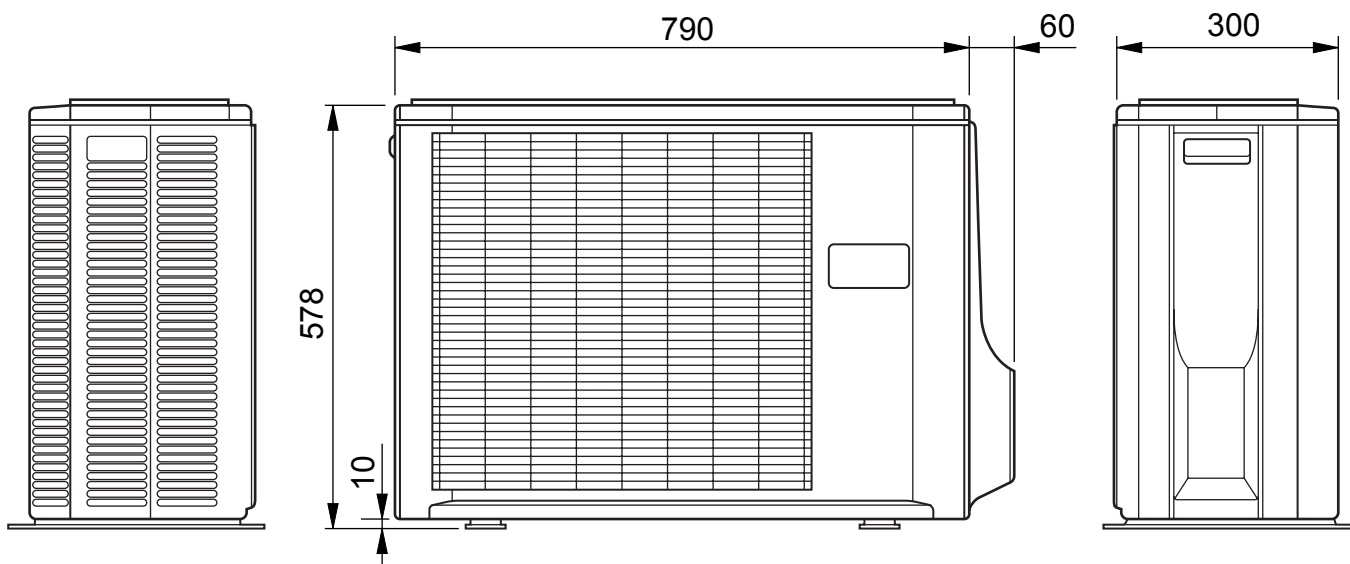
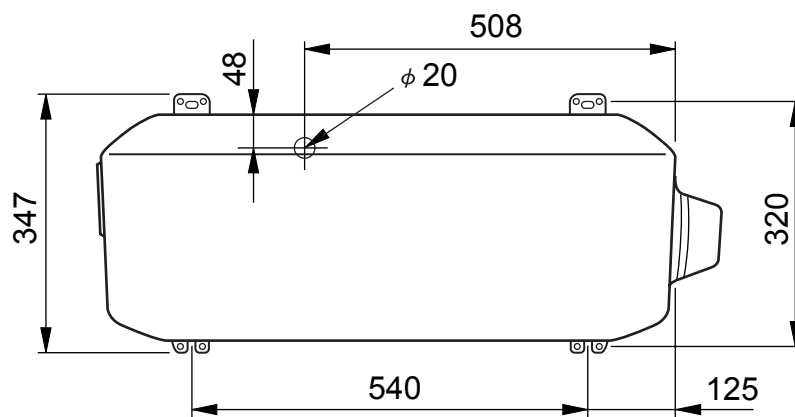
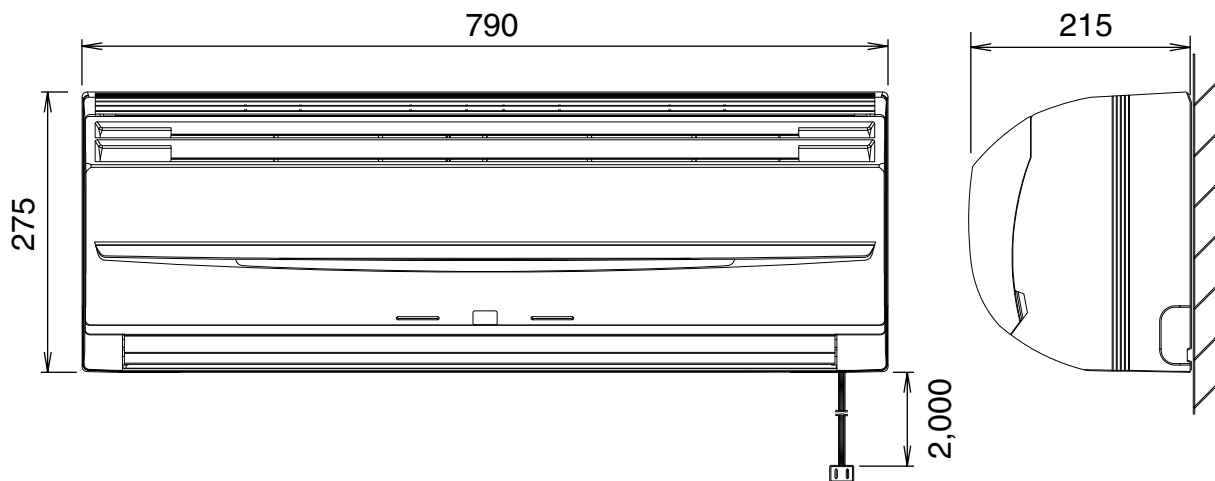

REFRIGERANT SYSTEM DIAGRAM

Models :
RSA14LCC / ROR14LCC
RSA18LCC / ROR18LCC

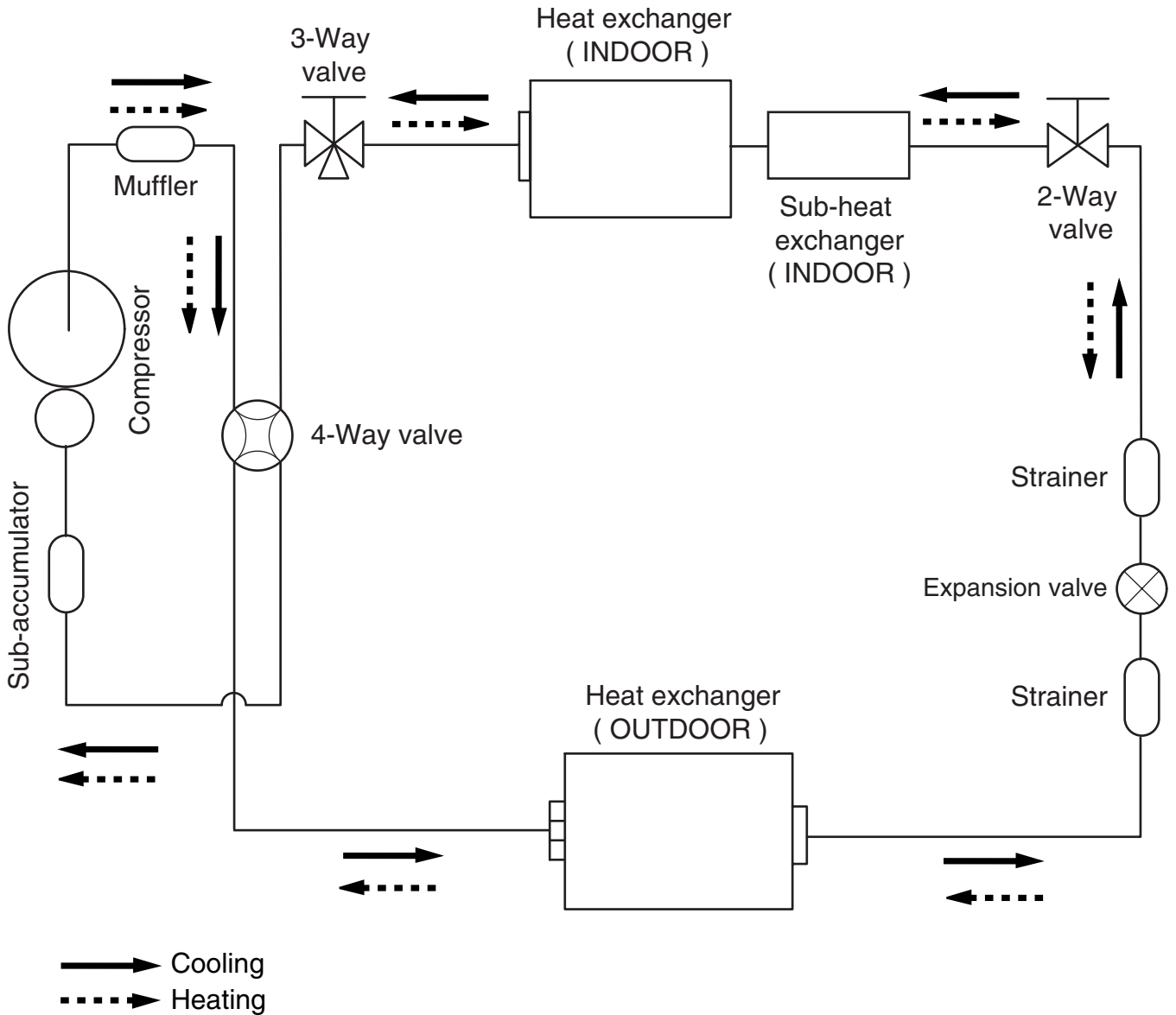

Refrigerant pipe diameter
Liquid : 1/4" (6.35 mm)
Gas : 1/2" (12.7 mm)

CIRCUIT DIAGRAM

Models :

RSA14LCC / ROR14LCC
 RSA18LCC / ROR18LCC

INDOOR UNIT

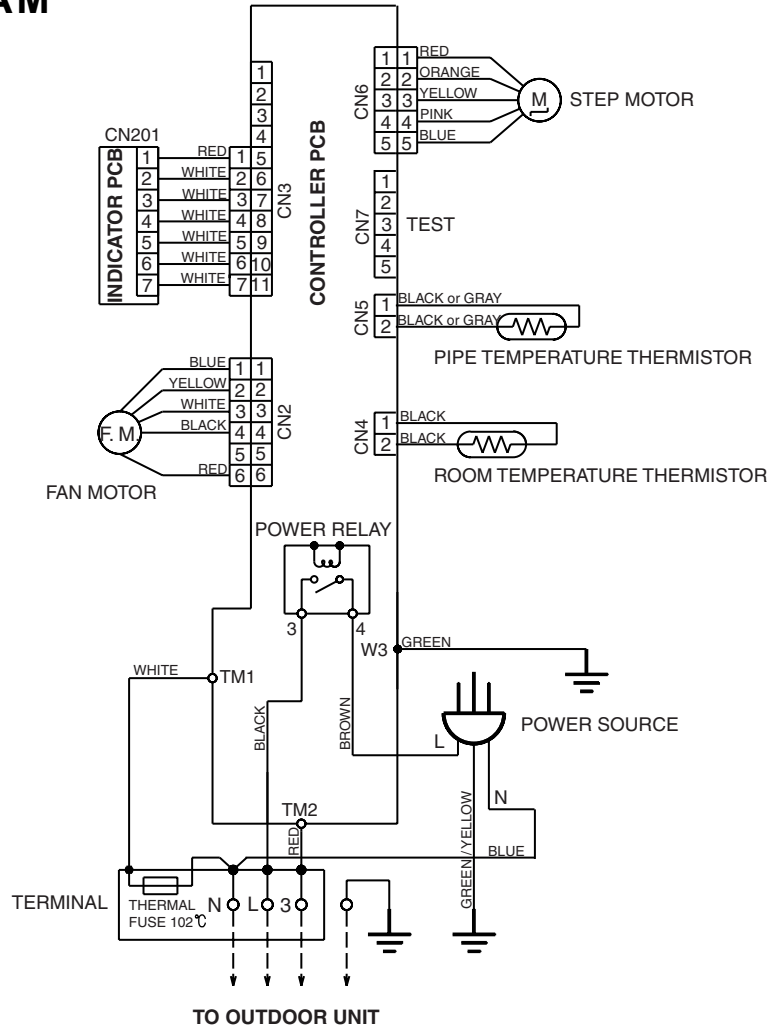

OUTDOOR UNIT

TO OUTDOOR UNIT

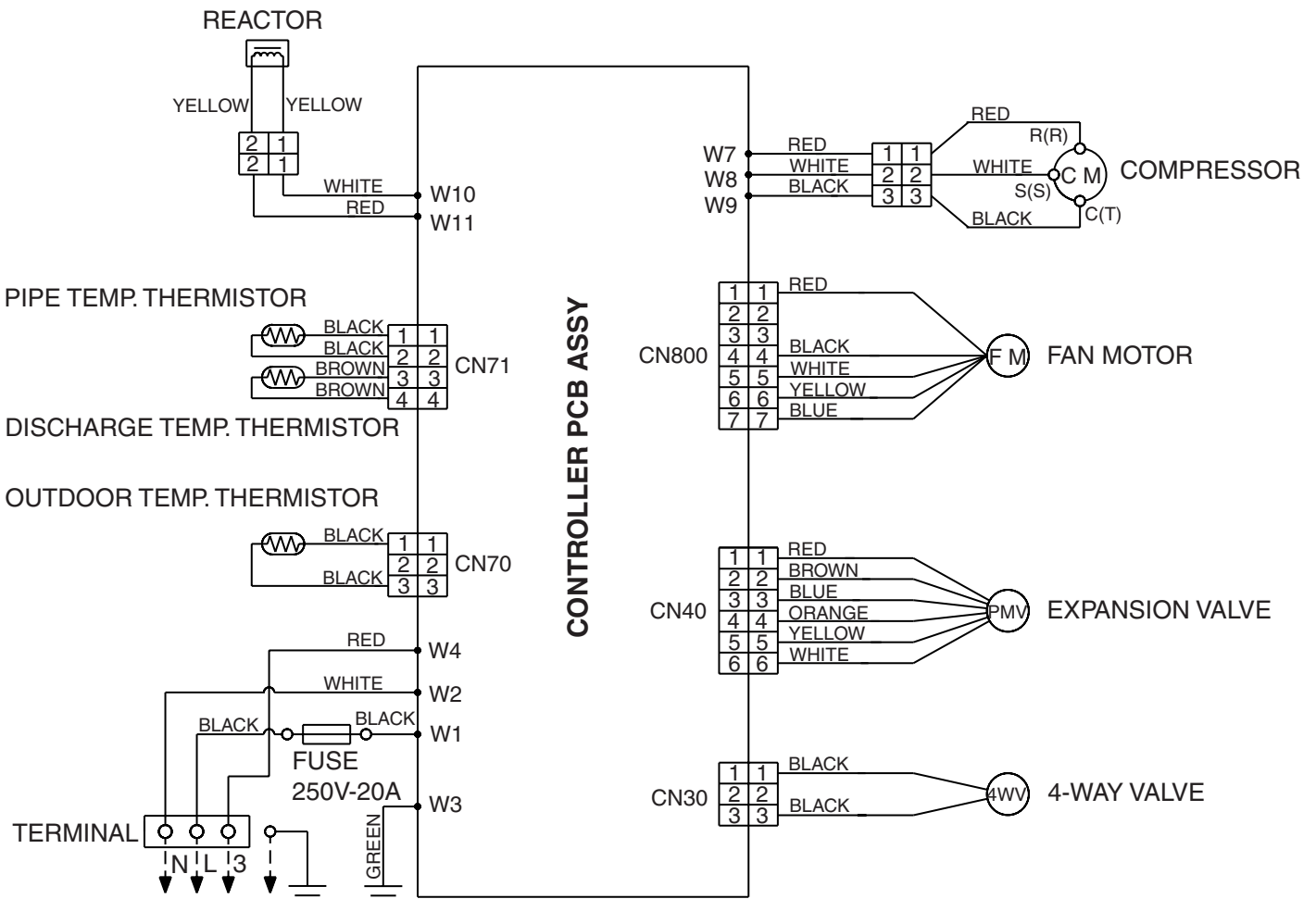

INDOOR PCB CIRCUIT DIAGRAM

Models :
RSA14LCC, RSA18LCC

TERMINAL BOARD

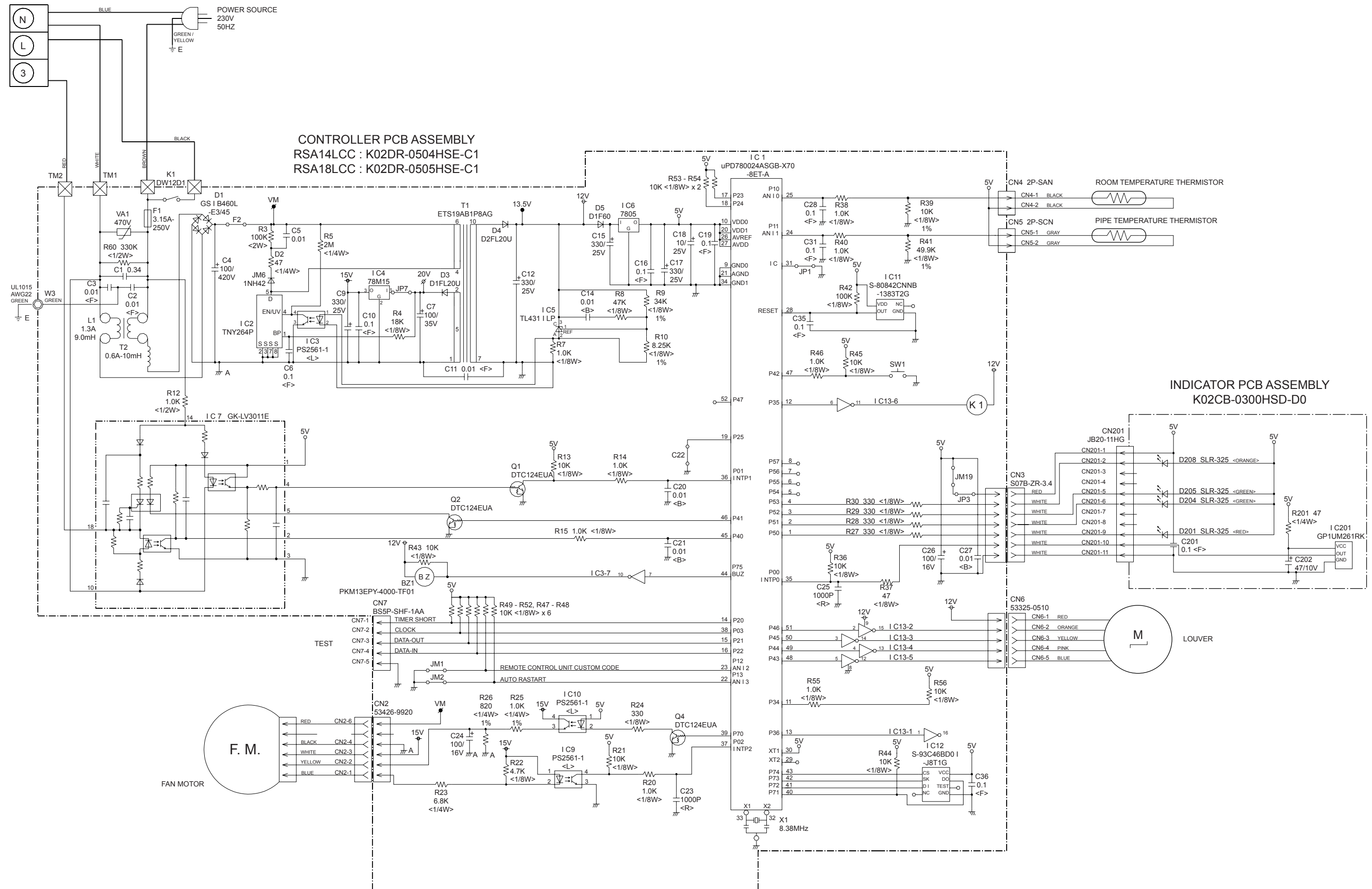

OUTDOOR PCB CIRCUIT DIAGRAM

Models :
ROR14LCC, ROR18LCC

INVERTER ASSEMBLY
ROR14LCC : EZ-0055HUE
ROR18LCC : EZ-005WHUE

CONTROLLER PCB ASSEMBLY
ROR14LCC : K05CM-0501HUE-C1
ROR18LCC : K05CM-0502HUE-C1

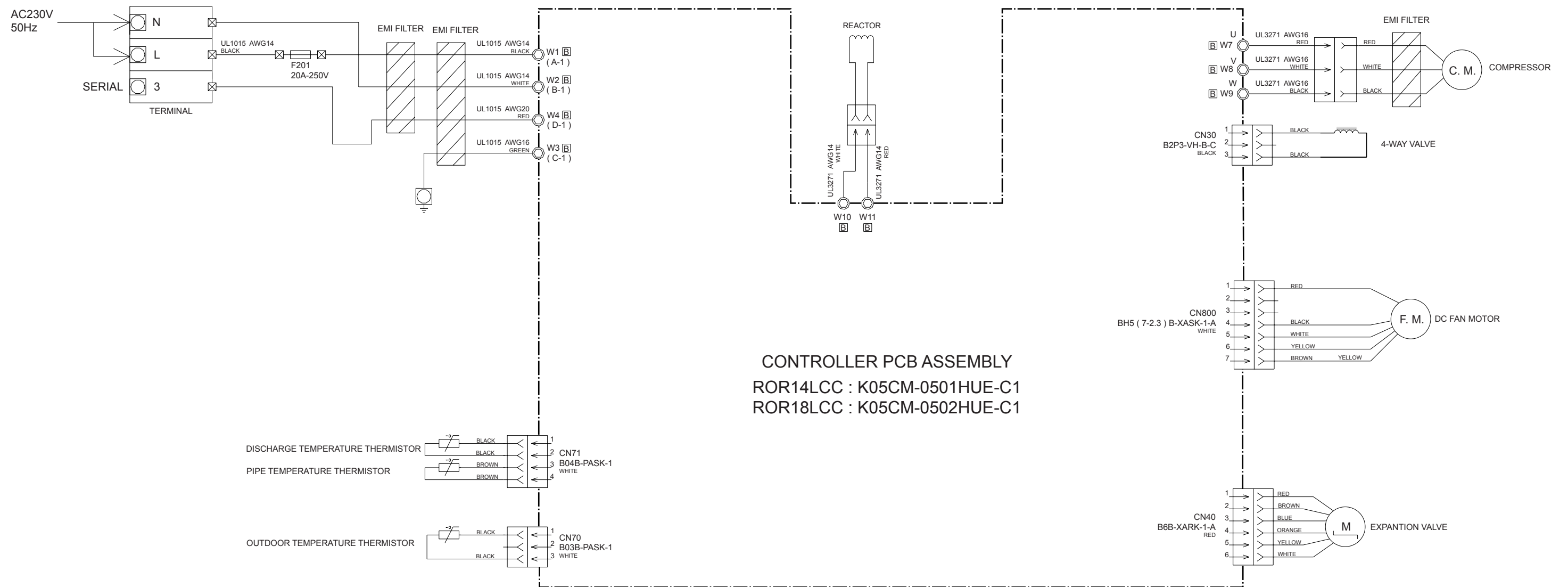

Models :
ROR14LCC, ROR18LCC

CONTROLLER PCB ASSEMBLY

ROR14LCC : K05CM-0501HUE-C1
ROR18LCC : K05CM-0502HUE-C1

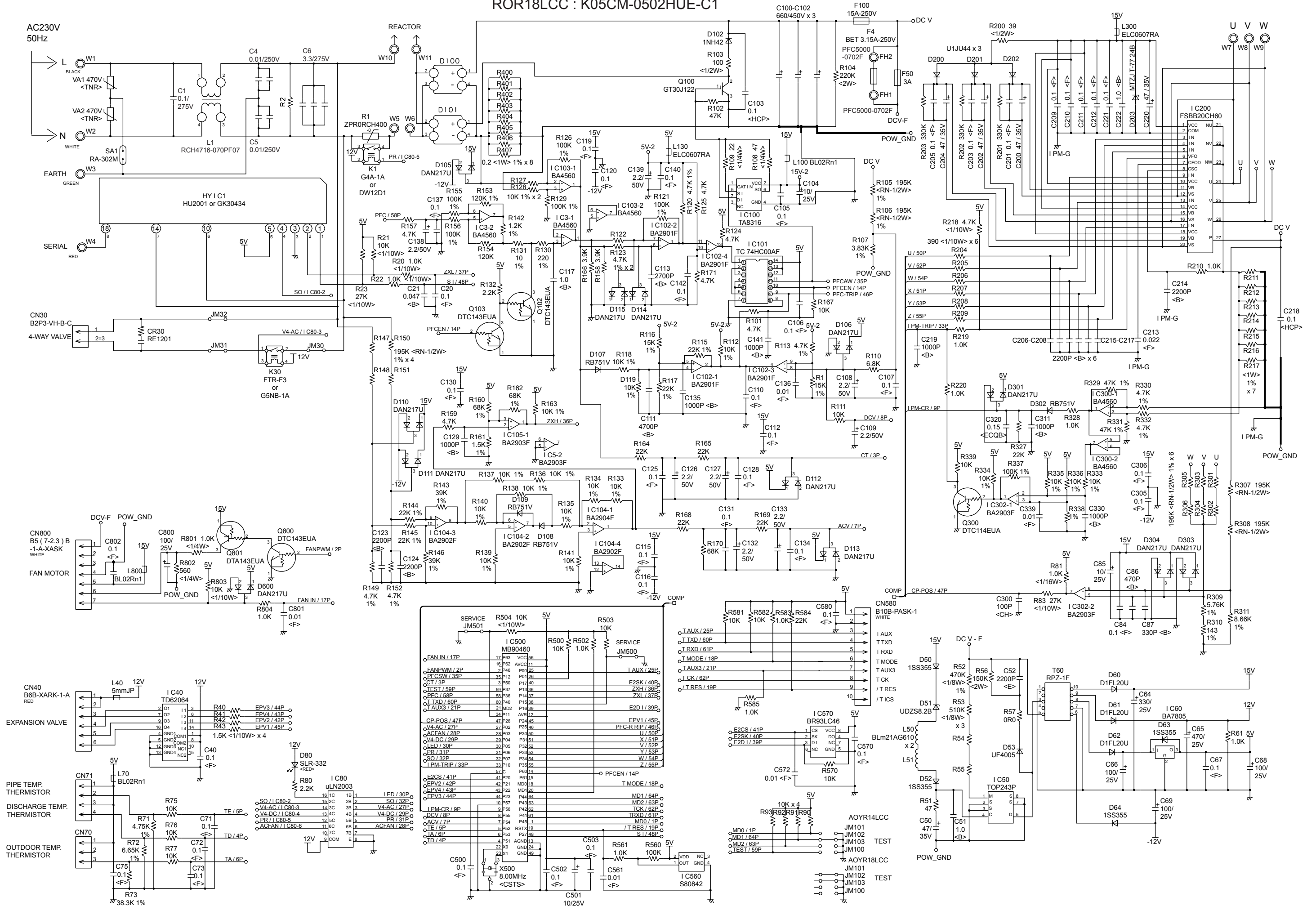

Все каталоги и инструкции здесь: <https://splitssystem48.ru/instrukcii-po-ekspluatatsii-kondicionerov.html>

ERROR CONTENTS

Model : HSA14LCC, HSA18LCC

Error	Display		Error
	Operation LED	Timer LED	
Serial signal error	Normal	2 flash	Serial signal (reverse) error, at operation start up
		3 flash	Serial signal (reverse) error, during operation
		4 flash	Serial signal (forward) error, at operation start up
		5 flash	Serial signal (forward) error, during operation
Indoor unit thermistor error	2 flash	2 flash	Indoor temperature thermistor open / short
		3 flash	Heat exchanger middle thermistor open / short
Outdoor unit thermistor error	3 flash	2 flash	Discharge thermistor open / short
		3 flash	Heat exchanger thermistor open
		4 flash	Outdoor temperature thermistor open / short
Indoor unit control error	4 flash	2 flash	Forced automatic SW welded
		3 flash	Main relay welded
		4 flash	Power interruption error
		7 flash	VDD permanent stop protection
		8 flash	reverse VDD permanent stop protection
Outdoor unit control error	5 flash	2 flash	Current trip error
		3 flash	CT abnormal
		5 flash	Compressor location detection error
		6 flash	Outdoor unit fan drive system abnormal
Indoor fan motor error	6 flash	2 flash	Abnormal lock
		3 flash	Abnormal rotation
Refrigerant cycle error	7 flash	2 flash	Discharge Temperature abnormal
		3 flash	Cooling high pressure abnormal rise
Optional function error	8 flash	4 flash	PFC circuit error
Model error	Blinking	Blinking	Model error

DISASSEMBLY ILLUSTRATION

Models :
RSA14LCC
RSA18LCC

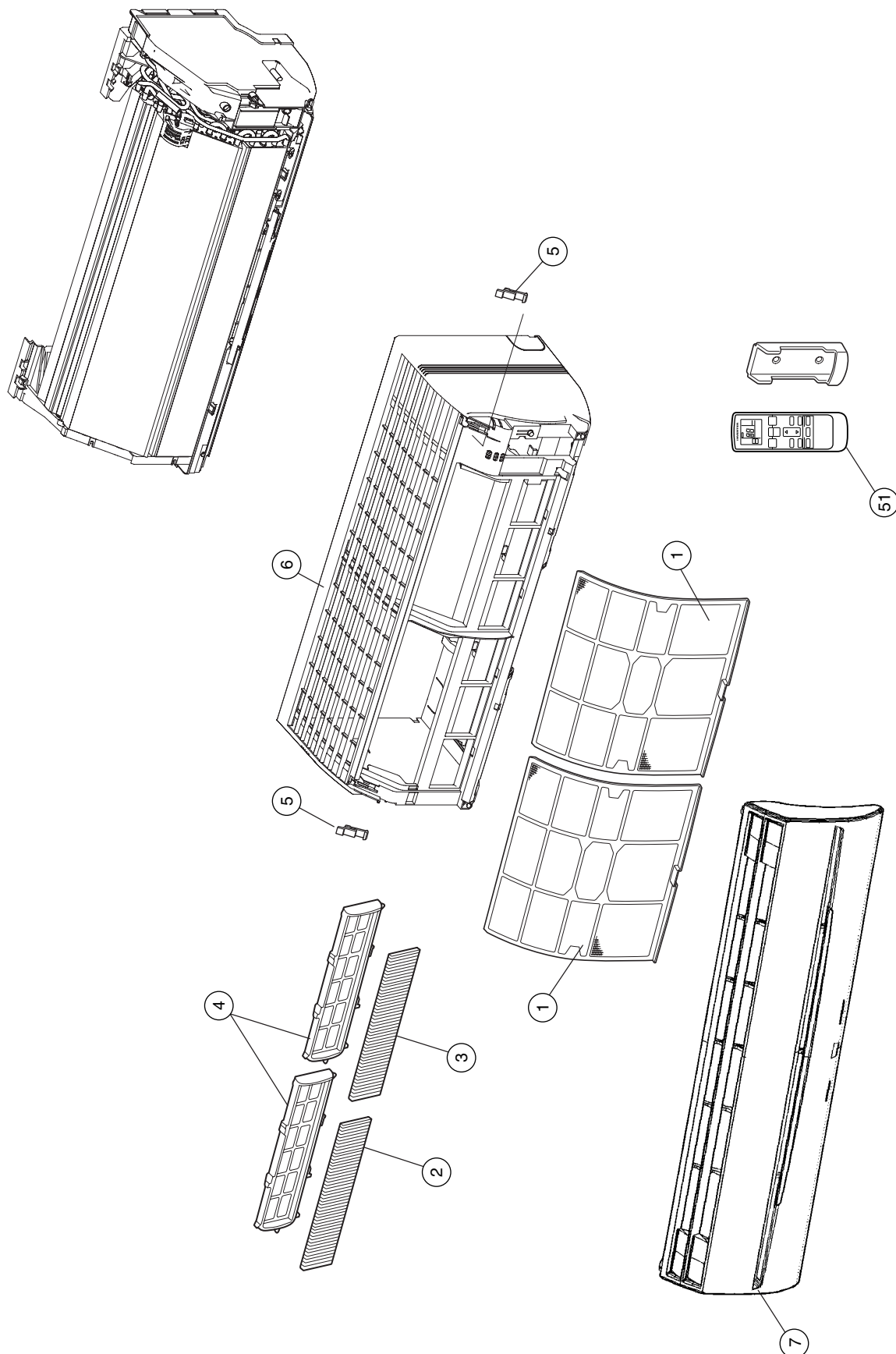

Models :
RSA14LCC
RSA18LCC

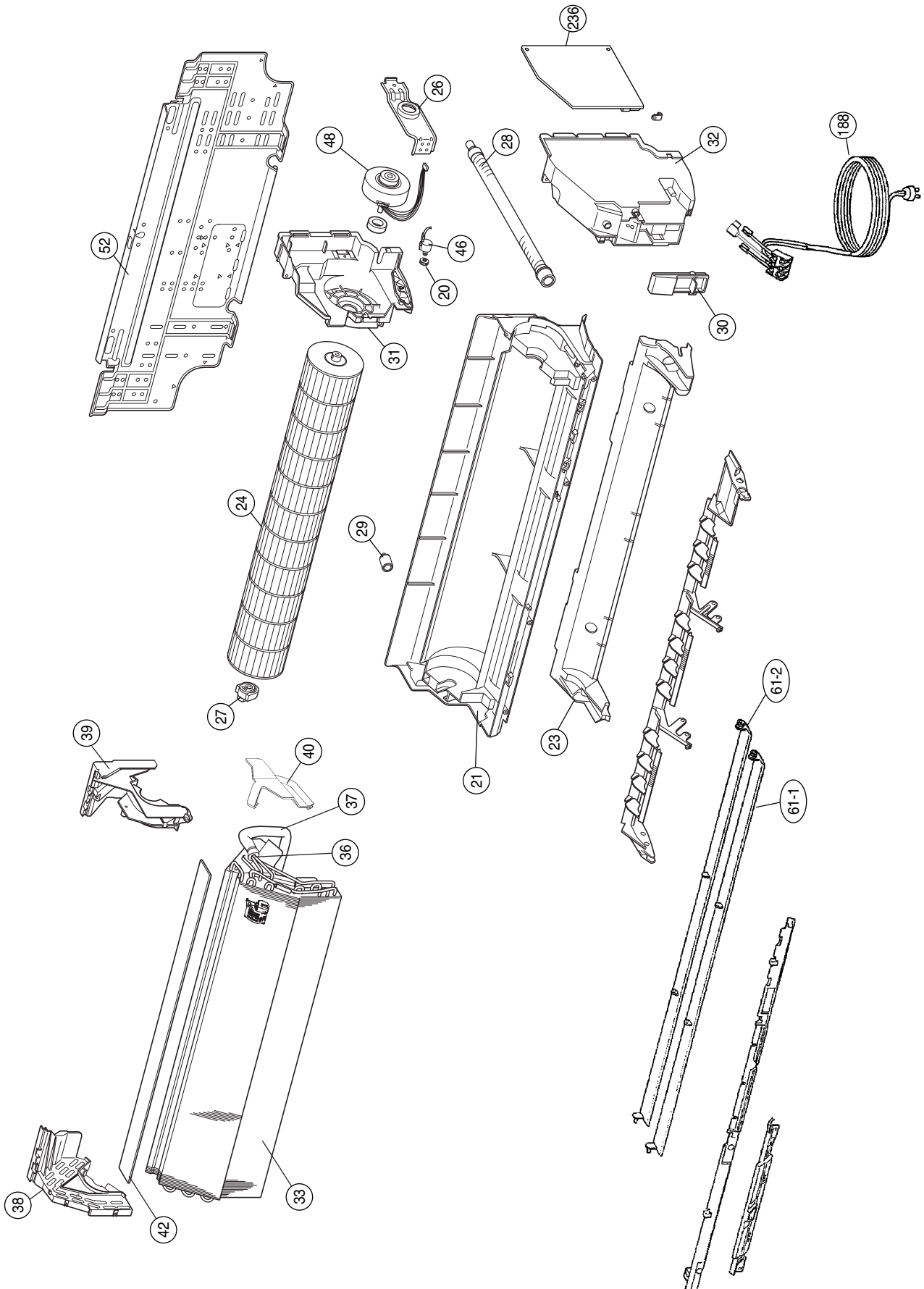

Models :
ROR14LCC
ROR18LCC

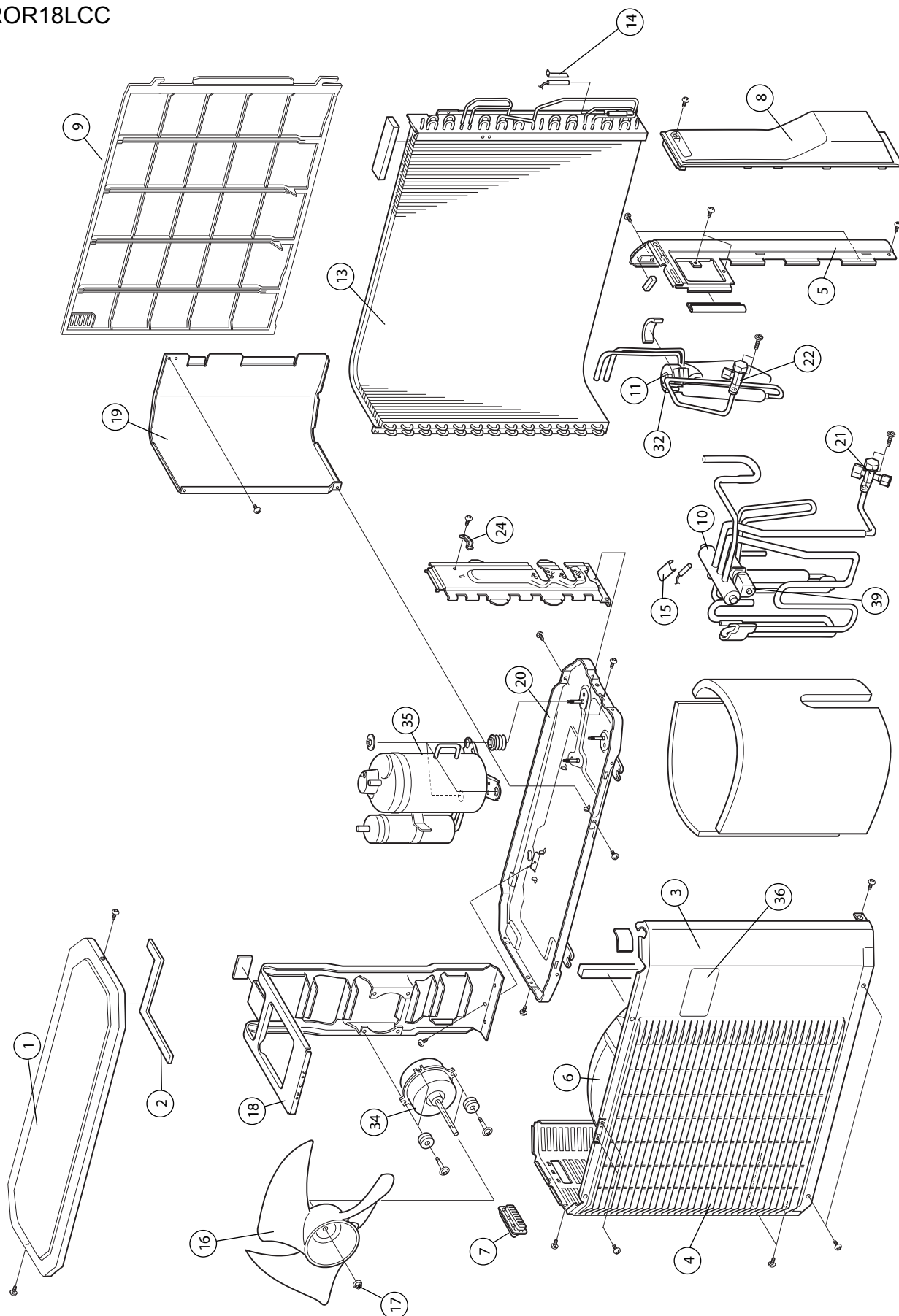

Model :
ROR14LCC
ROR18LCC

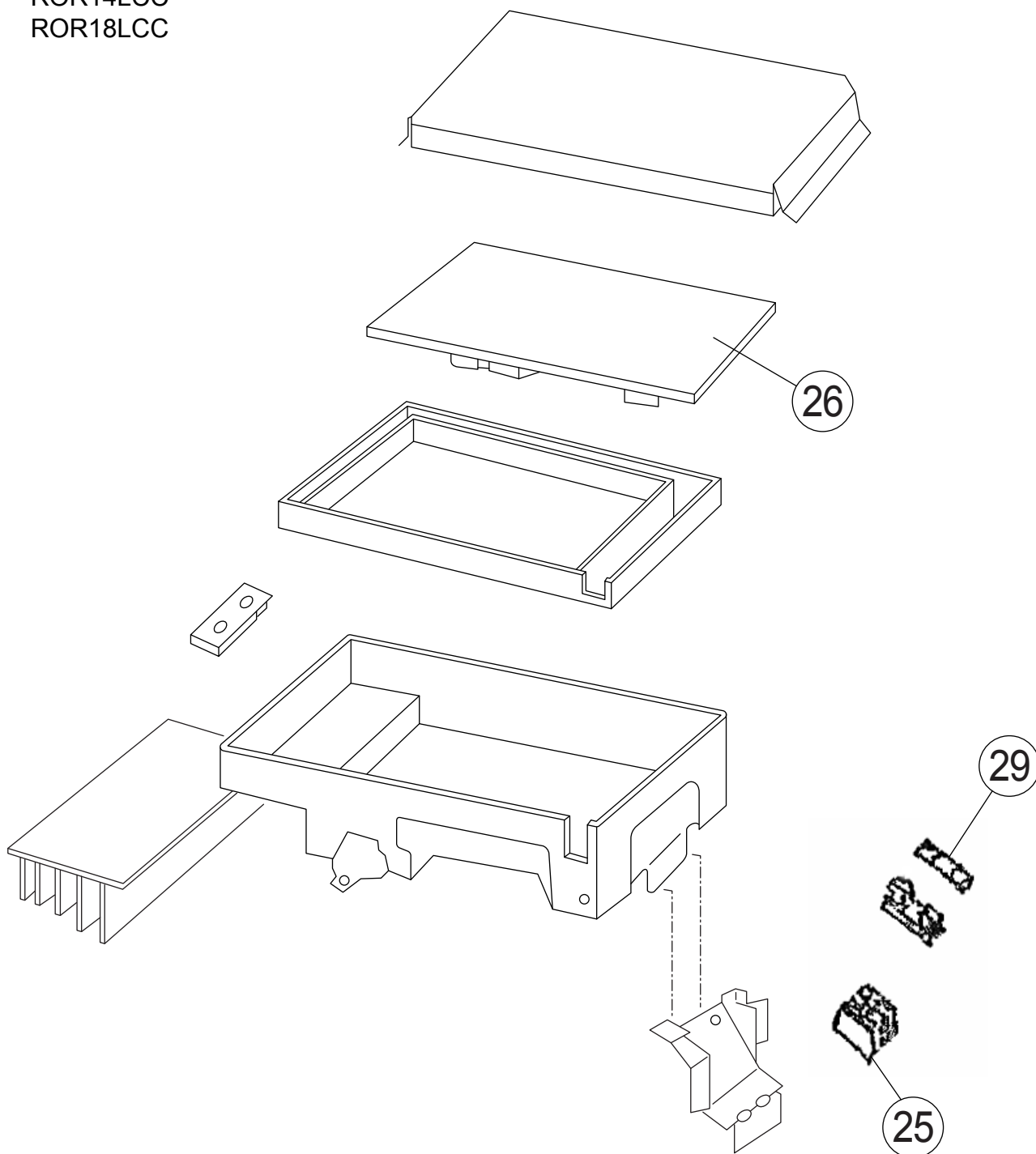

PARTS LIST





INDOOR UNIT

Ref. No.	Description	Part No.		Ord. Q'ty
		RSA14LCC	RSA18LCC	
1	Air Filter	9309997011	9309997011	
2	Filter (Electric)	9312153015	9312153015	
3	Filter (ION)	9311925033	9311925033	
4	Holder (Filter)	9306602017	9306602017	
5	Clamper (Grille)	9306755010	9306755010	
6	Front Panel Total Assy	9313130114	9313130114	
7	Intake Grille Assy	9313131074	9313131074	
20	Gear-A	9309994003	9309994003	
21	Casing Assy	9311354079	9311354079	
23	Cover (Casing)-B	9314160011	9314160011	
24	Crossflow Fan Assy	9307836015	9307836015	
26	Clamp (Motor)	9310102008	9310102008	
27	Shaft Holder-C Assy	9306628017	9306628017	
28	Drain Hose Assy	9314147012	9314147012	
29	Drain Cap Assy	9314493010	9314493010	
30	Wire Clamper	9311946014	9311946014	
31	Box (Switch)	9312908011	9312908011	
32	Cover (Switch)	9312909018	9312909018	
33	Evaporator Total Assy	9313099015	9313099015	
36	Joint Pipe Assy	9313792015	9313792015	
37	Insulation (Pipe)-E	9304607007	9304607007	
38	Holder (Evaporator)-L	9309982017	9309982017	
39	Holder (Evaporator)-R	9309983014	9309983014	
40	Water Seal	9312912018	9312912018	
42	Air Seal	9310611005	9310611005	
46	Step Motor	9900139025	9900139025	
48	Fan Motor Assy	9601814016	9601814016	
51	Remote Control Unit	9315027030	9315027030	
52	Bracket Panel	9310001004	9310001004	
61-1	Flow Control Panel-U	9309991033	9309991033	
61-2	Flow Control Panel-Z	9309992030	9309992030	
188	Power Cord Assy	9900339012	9900339012	
236	Controller PCB Assy	9705656116	9705656123	
		(K02DR-0504HSE-C1)	(K02DR-0505HSE-C1)	
---	Pipe Temperature Thermistor	9702039042	9702039042	
---	Room Temperature Thermistor	9700801108	9700801108	
---	Indicator PCB Assy	9705039032	9705039032	
---	Evaporator B Assy	9311275022	9311275022	

OUTDOOR UNIT

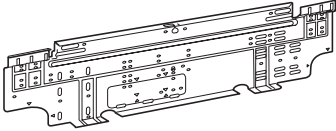
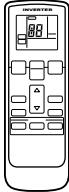
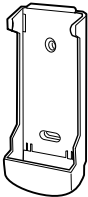
Ref. No.	Description	Part No.		Ord. Q'ty
		ROR14LCC	ROR18LCC	
1	Top Panel Assy	9309230057	9309230057	
2	Top Panel Seal	9309228016	9309228016	
3	Cabinet Assy	9314809040	9314809040	
4	Blow Down Grille	9308884015	9308884015	
5	Cabinet Right Assy	9309236011	9309236011	
6	Fan Ring	9308885012	9308885012	
7	Grip	9308880017	9308880017	
8	Switch Cover	9308882028	9308882028	
9	Protective Net	9315319012	9315319012	
10	4-Way Valve Assy	9315726018	9315726018	
11	Expansion Valve Assy	9311641018	9311641018	
13	Condenser	9311381037	9311381037	
14	Thermistor Spring-A	313728262708	313728262708	
15	Thermistor Spring	9300089012	9300089012	
16	Propeller Fan	9309909014	9309909014	
17	Nut	9304902003	9304902003	
18	Motor Bracket	9308872012	9308872012	
19	Separator Assy	9312971015	9312971015	
20	Base Assy, Painted	9308869081	9308869081	
21	3-Way Valve Assy	9315159014	9315159014	
22	2-Way Valve Assy	9313064013	9313064013	
24	Cord Clamp	9307271014	9307271014	
25	Terminal	9306489038	9306489038	
26	Inverter PCB Assy	9707039023	9707039030	
29	Fuse	0600382018	0600382018	
32	Expansion Valve Coil	9900057039	9900057039	
34	Fan Motor	9601725015	9601725015	
35	Compressor Assy	9313764012	9313764012	
36	Emblem	9312637034	9312637034	
39	Solenoid Coil	9970033018	9970033018	
---	IPM	9705720015	9705720015	
---	Thermistor Assy	9900148027	9900148027	
---	Outdoor Temp. Thermistor	9900210045	9900210045	

STANDARD ACCESSORIES

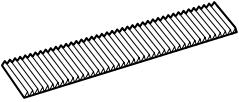
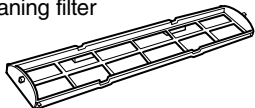
Name and Shape	Part No.
Wall hook bracket 	9310001004
Remote control unit 	9315027030
Remote control unit holder 	9305642045
Battery (penlight) 	0600185527
Cloth tape 	9310519004
Tapping screw (big) (ϕ 4 x 25) 	0700076046
Tapping screw (small) (ϕ 3 x 12) 	0700019036
Air cleaning filter 	9312153015 9311925033
Air cleaning filter frame 	9306602017



Большая библиотека технической документации

<https://splitsystema48.ru/instrukcii-po-ekspluatácii-kondicionerov.html>

каталоги, инструкции, сервисные мануалы, схемы.